



FK-280PA/SA



Carbon-brush motors

OUTPUT : 0.4W~20W (APPROX)

WEIGHT : 36g (APPROX)

Typical Applications Home Appliances
Precision Instruments : Printer / Vending Machine

MODEL	VOLTAGE		NO LOAD		AT MAXIMUM EFFICIENCY				STALL			
	OPERATING RANGE	NOMINAL	SPEED	CURRENT	SPEED	CURRENT	TORQUE	OUTPUT	TORQUE	CURRENT		
			r/min	A	r/min	A	mN-m	g-cm	W	mN-m	g-cm	A
FK-280PA-18165	10~15	12V CONSTANT	10500	0.090	9000	0.54	4.12	42.0	3.88	28.9	295	3.25
FK-280PA-10400	8~24	24V CONSTANT	8900	0.040	7360	0.19	3.38	34.5	2.60	19.6	200	0.92
FK-280SA-18165	10~15	12V CONSTANT	12300	0.075	10710	0.50	3.40	34.7	3.81	26.3	268	3.40

DIRECTION OF ROTATION

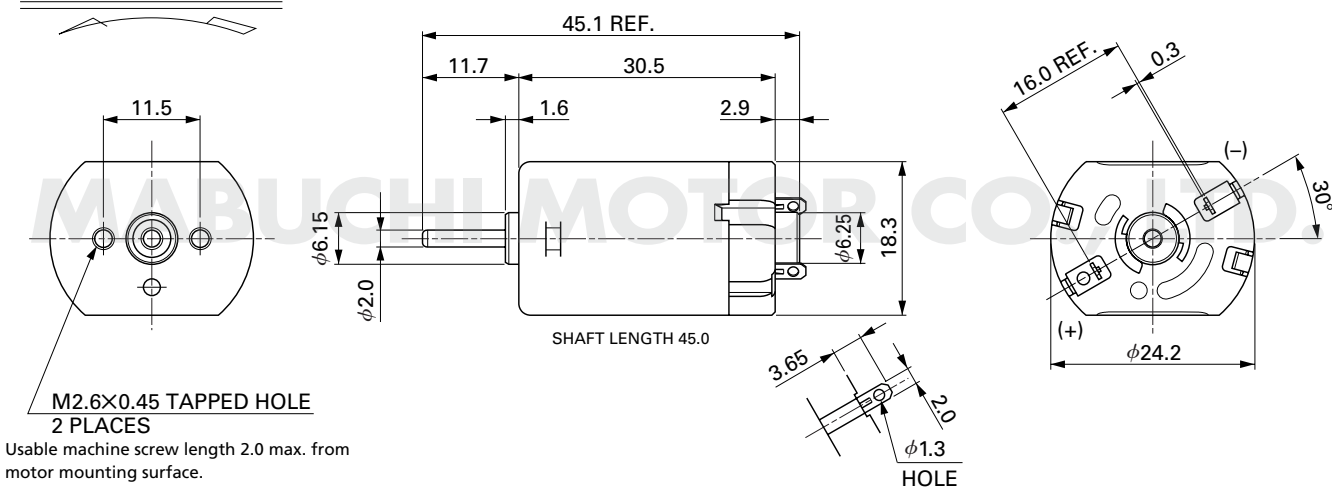

UNIT: MILLIMETERS

FK-280PA-18165

12.0V

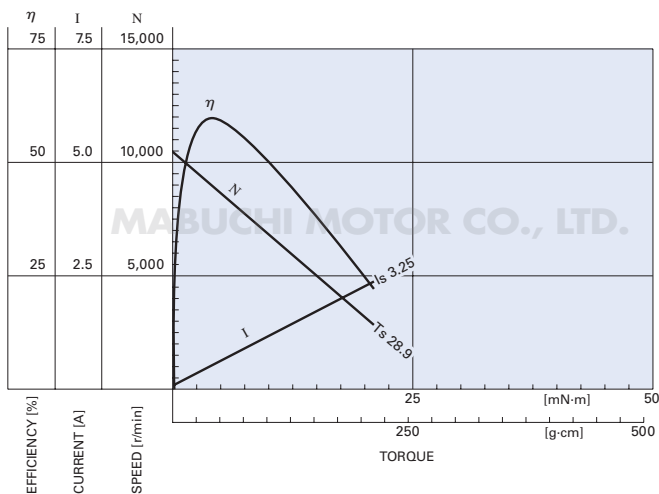

FK-280SA-18165

12.0V

