



RF-500TB



Precious metal-brush motors

OUTPUT : 0.01W~2.0W (APPROX)

WEIGHT : 45g (APPROX)

Typical Applications Audio and Visual Equipment : CD Player / DVD Player

MODEL	VOLTAGE		NO LOAD		AT MAXIMUM EFFICIENCY				STALL			
	OPERATING RANGE	NOMINAL	SPEED r/min	CURRENT A	SPEED r/min	CURRENT A	TORQUE mN-m	TORQUE g-cm	OUTPUT W	TORQUE mN-m	TORQUE g-cm	CURRENT A
RF-500TB-14415	1.5~9.0	5V CONSTANT	3100	0.026	2540	0.12	1.23	12.6	0.33	6.86	70	0.54
RF-500TB-12560	4~14	12V CONSTANT	5500	0.025	4630	0.13	1.79	18.2	0.86	11.3	115	0.71

DIRECTION OF ROTATION

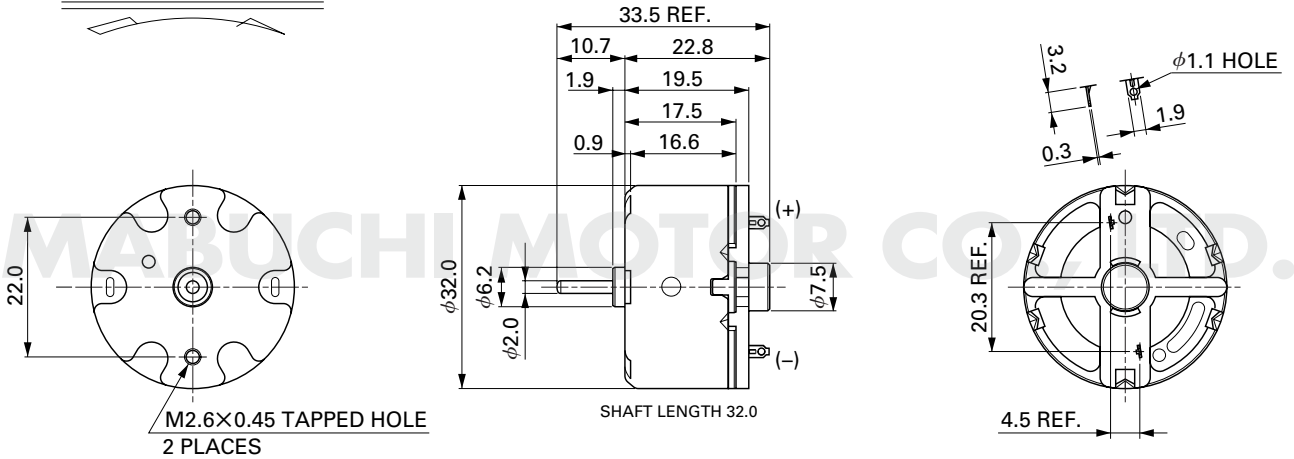

Usable machine screw length 1.5 max. from motor mounting surface.

UNIT: MILLIMETERS

RF-500TB-14415

5.0V

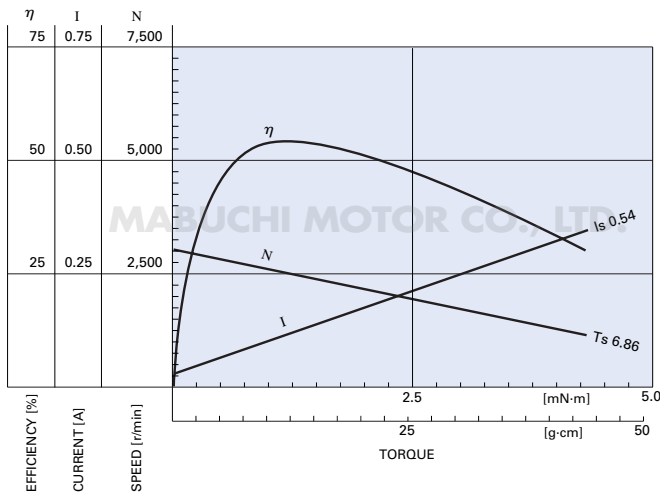

RF-500TB-12560

12.0V

