

RS-545SH



Carbon-brush motors

OUTPUT : 5.0W~75W (APPROX)

WEIGHT : 156g (APPROX)

Typical Applications Home Appliances : Hair Dryer / Massager / Vibrator / Vacuum Cleaner / Bilge Pump

MODEL	VOLTAGE		NO LOAD		AT MAXIMUM EFFICIENCY				STALL			
	OPERATING RANGE	NOMINAL	SPEED	CURRENT	SPEED	CURRENT	TORQUE		OUTPUT	TORQUE		CURRENT
			r/min	A	r/min	A	mN-m	g-cm	W	mN-m	g-cm	A
RS-545SH-18150	12~32	24V CONSTANT	5300	0.10	4390	0.48	15.2	155	6.97	88.3	900	2.32
RS-545SH-2860	6~24	12V CONSTANT	6800	0.25	5730	1.34	17.3	176	10.4	110	1121	7.20

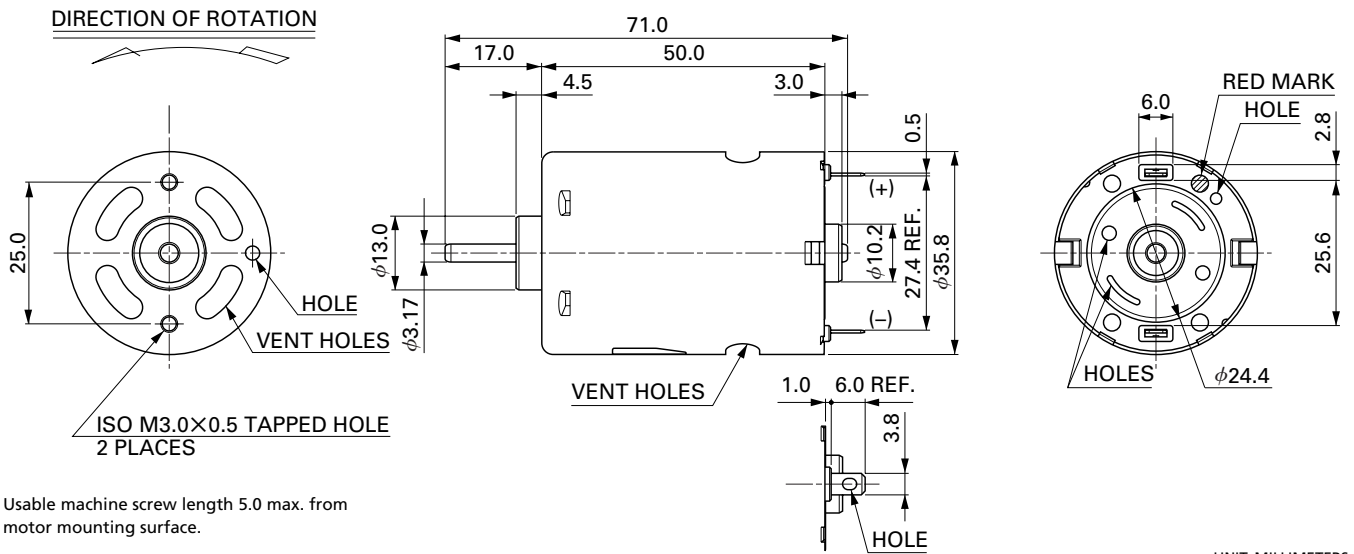

RS-545SH-18150 24.0V

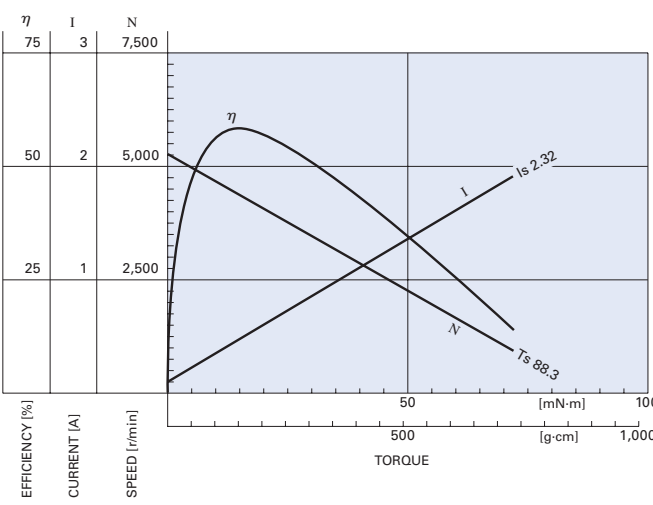

RS-545SH-2860 12.0V

