

FF-K10WA-5Z215 (ブラシ付モータ)

Weight : Approx. 1.6g



特長と仕様

- 低騒音
- 低コギング
- 希土類マグネット

MODEL	VOLTAGE		NO LOAD			AT MAXIMUM EFFICIENCY				STALL			
	OPERATING RANGE	NOMINAL	SPEED	CURRENT	SPEED	CURRENT	TORQUE		OUTPUT	TORQUE		CURRENT	
		V	r/min	A	r/min	A	mN·m	g·cm	W	mN·m	g·cm	A	
FF-K10WA	5Z215	2.5 - 3.5	3	20500	0.057	13870	0.12	0.061	0.63	0.089	0.19	1.9	0.25

DIRECTION OF ROTATION

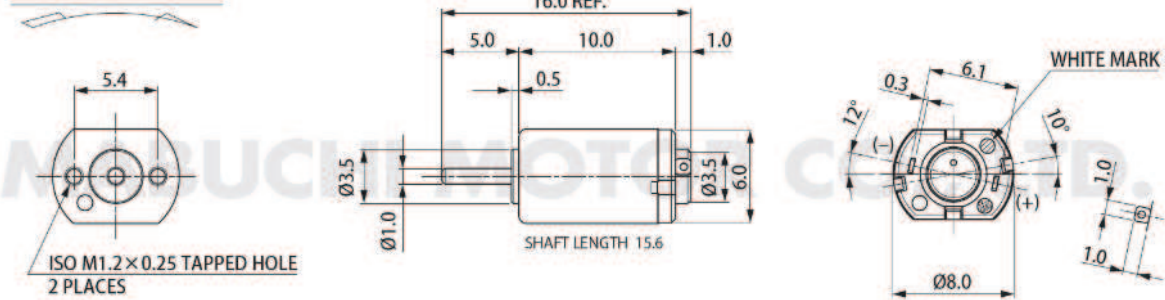

取り付けネジの長さはモータケース面より1.0以下

UNIT : MILLIMETERS

FF-K10WA-5Z215 3.0V

