

FF-K20WD-09101 (ブラシ付モータ)

Weight : Approx. 2.4g



特長と仕様

- 低騒音
- 低コギング
- 希土類マグネット

MODEL	VOLTAGE		NO LOAD			AT MAXIMUM EFFICIENCY				STALL			
	OPERATING RANGE	NOMINAL	SPEED	CURRENT	SPEED	CURRENT	TORQUE		OUTPUT	TORQUE		CURRENT	
		V	r/min	A	r/min	A	mN·m	g·cm	W	mN·m	g·cm	A	
FF-K20WD	09101	1.5 - 3.5	2.8	22200	0.054	17230	0.19	0.13	1.3	0.23	0.58	5.9	0.65

DIRECTION OF ROTATION

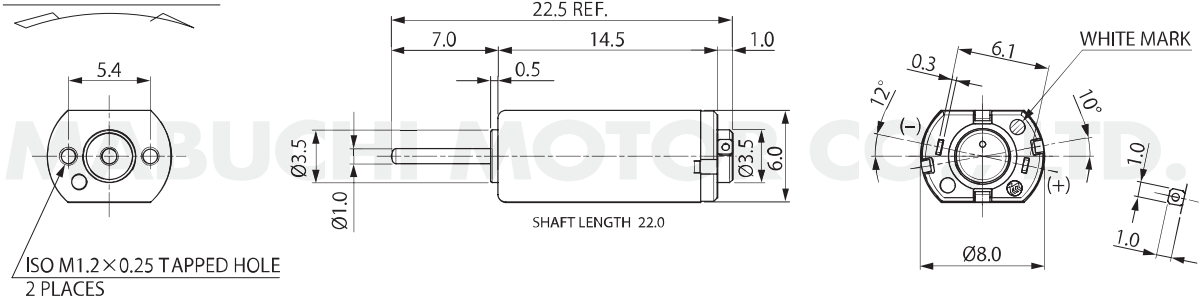

取り付けネジの長さはモータケース面より0.8~1.1

UNIT : MILLIMETERS

FF-K20WD-09101 2.8V

